

(No Model.)

G. W. KAMERER.
TOOL FOR DRESSING EMERY WHEELS.

No. 511,083.

Patented Dec. 19, 1893.

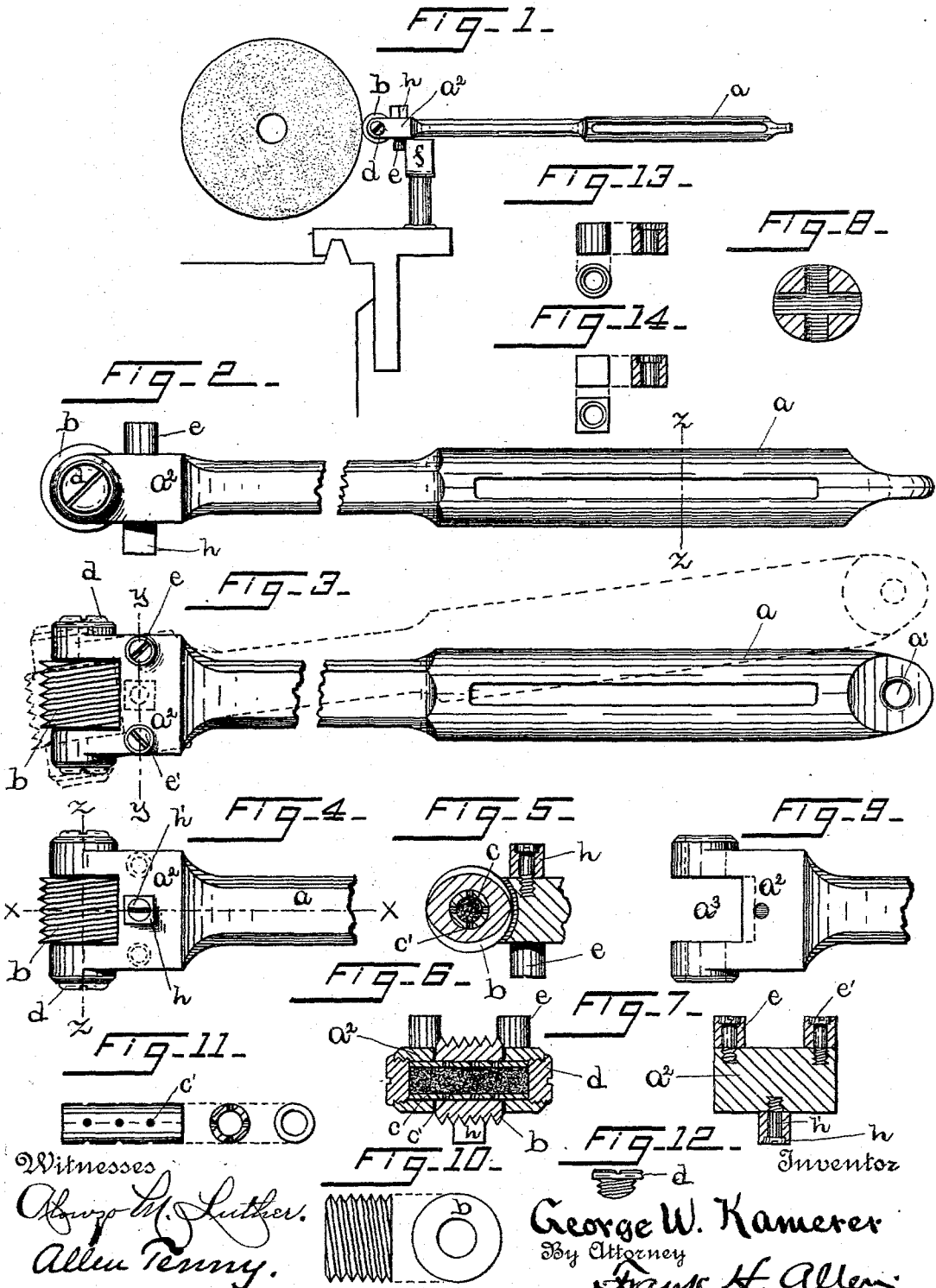

Witnesses
Alvyn M. Luther.
Allen Penny.

George W. Kamerer
 By Attorney
Frank H. Allen

UNITED STATES PATENT OFFICE.

GEORGE W. KAMERER, OF NORWICH, CONNECTICUT.

TOOL FOR DRESSING EMERY-WHEELS.

SPECIFICATION forming part of Letters Patent No. 511,083, dated December 19, 1893.

Application filed April 10, 1893. Serial No. 469,736. (No model.)

To all whom it may concern:

Be it known that I, GEORGE W. KAMERER, a citizen of the United States, residing at Norwich, in the county of New London and State of Connecticut, have made certain new and useful Improvements in Tools for Dressing Emery-Wheels, which improvements are fully set forth and described in the following specification, reference being had to the accompanying drawings.

My invention relates to devices for truing up emery wheels and has for its object the production of a tool which may be more easily controlled than those now in common use and which shall be in a measure self oiling. I have also improved various details of such tools, all being described hereinafter.

In the annexed drawings, Figure 1 shows an emery wheel, portion of a lathe bed, a tool-supporting carriage mounted thereon, and an emery wheel dresser of my improved form. Figs. 2 and 3 are, respectively, side and plan views of said dresser, enlarged to nearly full size, and Fig. 4 is a view of the head portion of said dresser showing the side opposite that of Fig. 3. Fig. 5 is a sectional view on line $x-x$ of Fig. 4 and Fig. 6 is a sectional view on line $z-z$ of the same figure. Fig. 7 is a cross sectional view on line $y-y$ of Fig. 3 and Fig. 8 shows a cross section of the handle of the tool at line $x-x$ of Fig. 2. Fig. 9 is a plan view of the head portion of the tool and Fig. 10 shows side and end views of a threaded roll which is revolubly mounted in said head upon a hollow axle, which latter is illustrated by side, cross sectional, and end views in Fig. 11. Fig. 12 shows one of the screws which I employ to retain said axle in place within the tool head. Fig. 13 shows side, sectional, and end views of anti-friction rolls which I provide on one side of the tool-head and Fig. 14 shows similar views of a block h which I provide upon the opposite side of said head and which serves as a fulcrum upon which the tool may be rocked when in use.

In the drawings the letter a indicates the handle of my improved tool, the same being preferably cored and chambered as shown in Fig. 8 to lighten it somewhat, and the extreme end of said handle is perforated, as at a' , to

provide an opening by means of which the tool may be hung up when not in service. The opposite end of the tool is formed as a head, or block a^2 of general rectangular shape, having its outer portion formed with a recess a^3 of sufficient size to receive a roll b which is here shown as threaded throughout its entire length and mounted upon a hollow axle c , whose ends are supported in the projecting portions of head a^2 , as best seen in Fig. 6 of the drawings. These projecting portions of the head are drilled to receive said axle and are also tapped at each end to receive screws d which, when they are screwed home, abut the hollow axle and serve both to exclude dirt and grit and also to prevent oil from oozing from said axle. When about to assemble the axle and cutting roll of my device I first pack the cavity in the axle with wool, sponge or other similar porous material and saturate the same with oil. I then provide one or more radial openings c' , leading outward from the oil reservoir thus provided, and through these openings the oil may reach the periphery of the axle to lubricate the axial bearing of the roll b . The supply of oil may be renewed when necessary by simply removing one of the screws d and injecting oil into the axle opening until the wool or other packing is again saturated.

Upon one face of the head a^2 are two rolls e that are loosely mounted upon screws e' . When my improved tool is in use these rolls bear upon the back side of the tool-rest f of the lathe, as seen in Fig. 1, and when it is desired to move the complete tool sidewise to true up the flat face of a wide emery wheel, these rolls e revolve upon their supporting screws e' , instead of binding as in the case of a stud formed as a rigid part of head a^2 as now used. By thus reducing friction the tool may be more easily controlled and a better result obtained. For use in dressing emery wheels having a half round face I provide upon the opposite side of head a^2 a single rectangular block h , located midway of the length of the roll b , and loosely supported by and upon a screw h' . When the tool is in use this block h bears upon the back side of the lathe tool-rest and serves as a fulcrum upon

which the tool may be rocked as indicated in dotted lines in Fig. 3.

My described improvements add greatly to the efficiency of this class of tools without
5 materially increasing their cost.

What I claim is—

1. An emery wheel dresser of lever form consisting of a handle having revolubly mounted therein a threaded dressing roll, and having
10 a fulcrum consisting of anti-frictional rolls secured adjacent to said dressing roll, substantially as and for the purpose specified.

2. An emery wheel dresser of lever form, consisting of a handle having revolubly mounted
15 in one end a dressing roll, and having a fulcrum consisting of a centrally located, loosely

mounted, block *h*; substantially as and for the purpose specified.

3. In an emery wheel dresser, in combination, a handle, a dressing roll, a fulcrum consisting of anti-frictional rolls as set forth, an
20 axle for said dressing roll formed as a tube with radial openings, a packing of porous material within said tube, and screws tapped
25 into the said handle and abutting the said axle; all being substantially as and for the objects specified.

GEORGE W. KAMERER.

Witnesses:

FRANK H. ALLEN,
ALONZO M. LUTHER.